

GALVA GEAR

Installation Manual

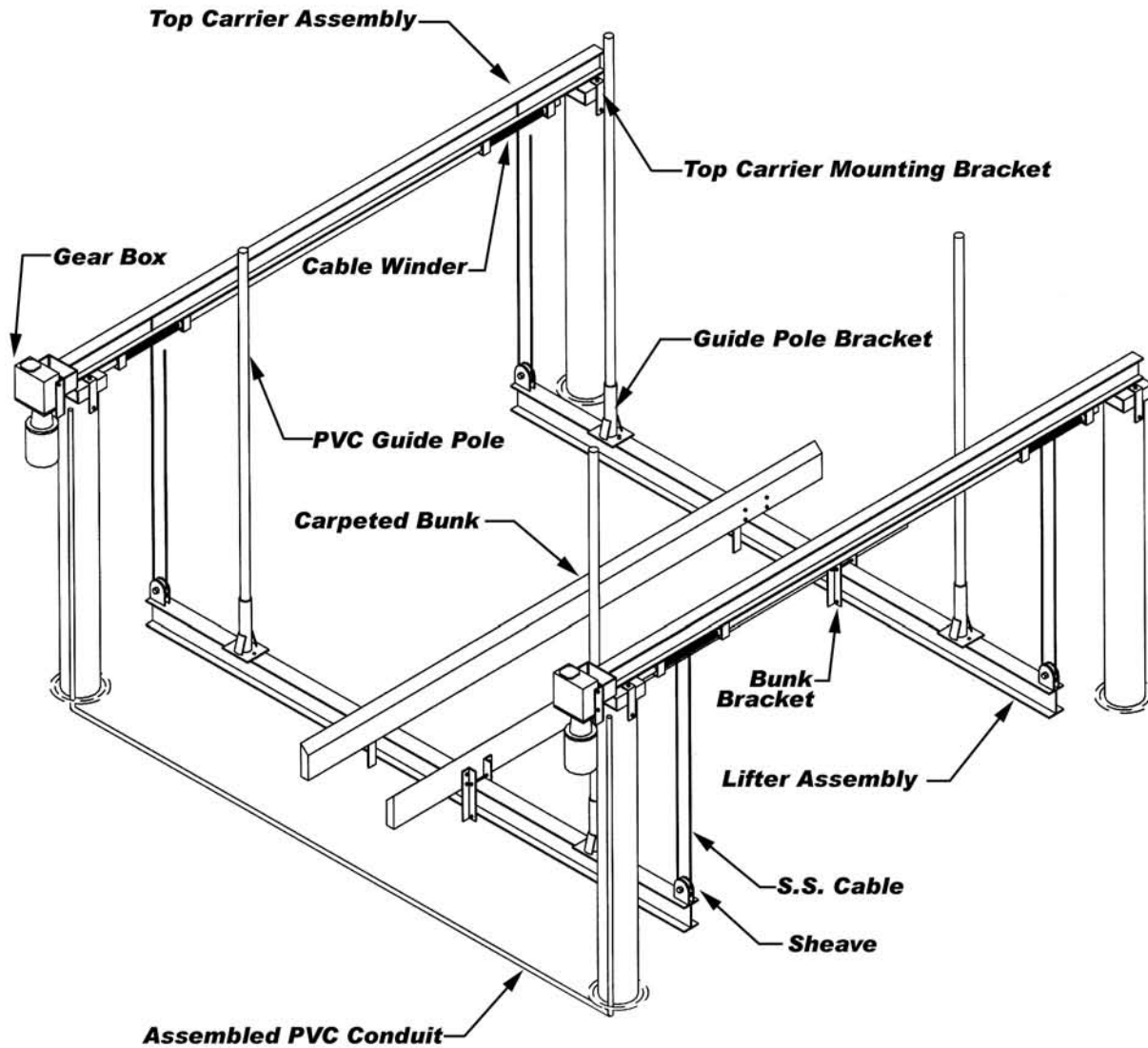

www.hi-tide.com

4050 Selvitz Road • Fort Pierce, Florida 34981

(772) 461-4660 1-800-544-0735 Fax (772) 461-2298

INTRODUCTION

At Hi-Tide Sales, we take pride in bringing the most advanced, easy to use, minimum maintenance boat lift system to the market today. The Installation of this lift is spimplified by its lightweight design and simple operation. In the pages that follow, we will take you step-by step through the entire installation sequence, including the lifting of the boat. We urge you to read this manual before attempting an installation.

Before you begin...

The GALVA-GEAR can be mounted to either concrete or wood pilings. The pilings are the foundation of the boat lift and must be able to carry the load of the lift and the boat to be lifted. Local or National code and common practice varies from area to area. Consult the GALVA-GEAR sales literature or call Hi-Tide for appropriate piling layout diagrams.

Step 1: Setting of Top Carriers

A. Scaffold and cut pilings to equal height and level tops.

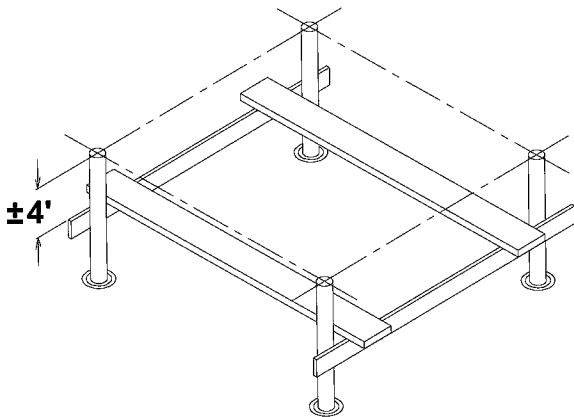

B. Attach mounting brackets to top carriers. Leave nuts loose.

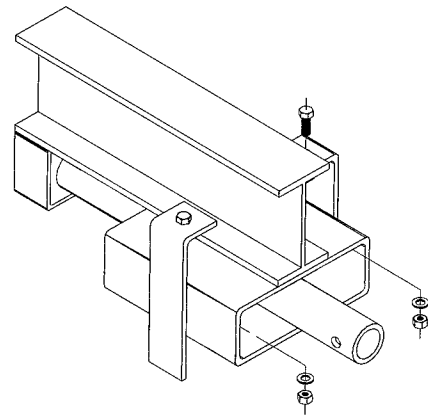

C. Pre-drill 1/4" hole in pilings and mount top carriers using lag bolts.

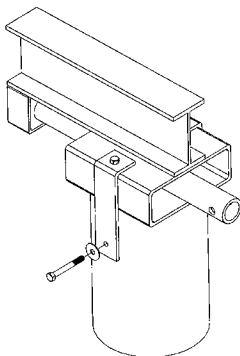

Concrete Pilings: Pre-drill 3/8" hole and install concrete anchor bolts.

D. Insure top carriers are level and square, then tighten all bolts.

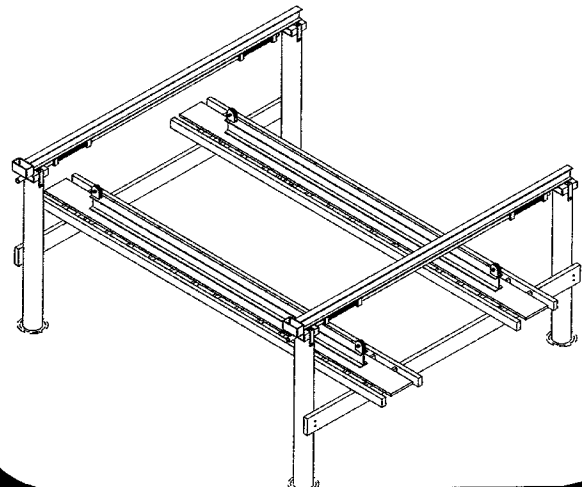

Step 4: Cable Routing and Clamping

Place Lifter Beams on scaffolding below winding areas as pictured in Diagram D (Previous step). Attach shackle then route cables as pictured according to the applicable chart below.

Important Note: On all applications, the lift cable will descend off of the outer side of winder and wind onto the spool toward the drive unit.

E. 4,000 - 6,000 Lbs.

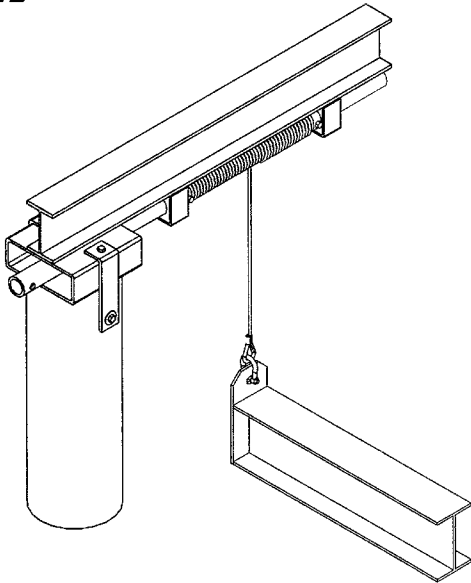

F. 9,000 - 16,000 Lbs.

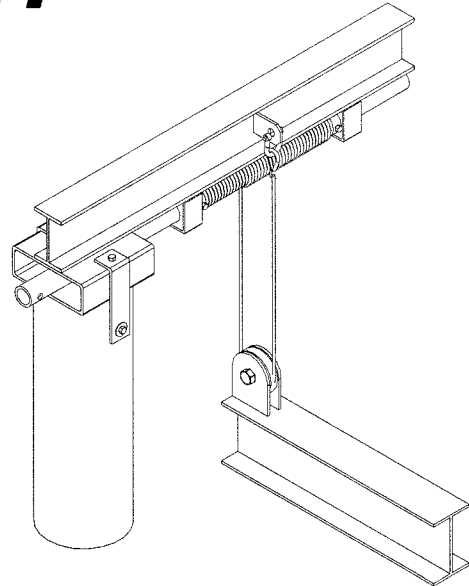

G.

Cable Clamp Installation

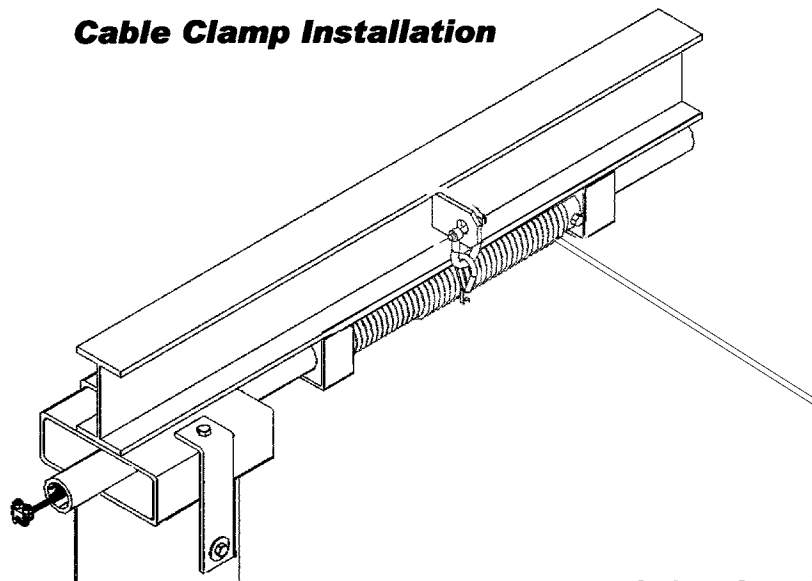

Insert cable into winder hole and push until cable emerges from end of pipe. Attach cable clamp and pull cable back until clamp rests against the backside of the winder hole. Lift cables should be adjusted such that the boat sits on the cradle at the same attitude as the boat sits in the water to assure good rain drainage. For typical installation, shorten bow cables as follows: 4,000 Lb. - 6,000 Lb. = Approx. 2", 9,000 Lb. - 16,000 Lb. = Approx. 4"

Step 2: Attaching Drive Unit

H. Install Gearbox with supplied hardware.

I. Drive pin will remain slightly loose in shaft. Tighten all Drive Unit bolts.

Step 3: Wiring the Lift

Boat Lift Electrical Requirements

Having the proper electrical service to your boat lift is critical to the satisfactory operation of the lift. As a minimum the following copper wire sizes must be observed to preclude possible voltage drop and damage to electrical components.

Motor H.P.	100 Feet 120V 240V	200 Feet 120V 240V	300 Feet 120V 240V	400 Feet 120V 240V
(2) 1/2 - 1 HP	#8 #10	#6 #10	#4 #10	#2 #8

Measure center distance of piling and assemble PVC conduit on land while threading the electrical wire through at the same time. A light spray of lubricant such as WD40 will make wire threading easier. Attach conduit to pilings as pictured on cover. Follow wiring instructions affixed to motors and/or remote controls if applicable. Test switches in up direction. If necessary, follow wiring diagrams on side of motor to reverse direction of motors. With correct wiring, cables should descend off the winder toward the outside of lift and wind toward the drive unit.

Important Notes:

- When at all possible, electrical services should be dedicated to the boat lift only to avoid interference by other electrical appliances.
- Please do not change or ignore wiring diagrams, or instructions as shown. There may be other ways to make it work, but our way is the only way approved by us (the Manufacturer).
- All lifts 16,000 Lbs. must be wired for 240V for proper operation.
- The wiring suggestions and wiring diagrams referred to are not meant to supersede any national or local codes.
- Hi-Tide recommends electrical work to be performed by a licensed electrical contractor.

Step 5: Constructing the Lift Cradle

Wind cables and allow lifter beams to hang freely. Measure lifter beam center distance. This should also be equal to winder center distance.

J. Mount carpeted bunks to lifter beams in order to retain lifter beam center distances.

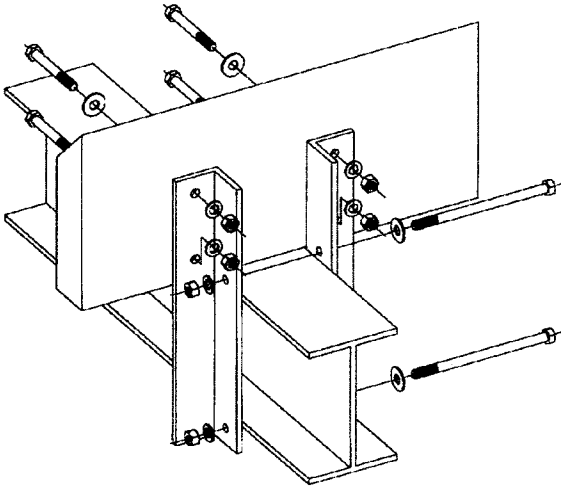

Some lifts are supplied lead weights. Attach lead weights to carpeted bunks.

K. Attach guide pole brackets, weight pipe, and guide poles.

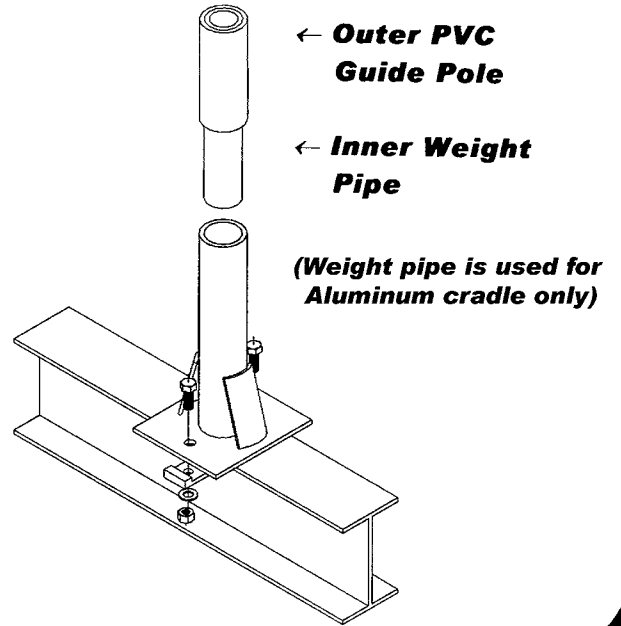

(Weight pipe is used for Aluminum cradle only)

Step 6: Completing the Installation

L. Low profile motor cover.

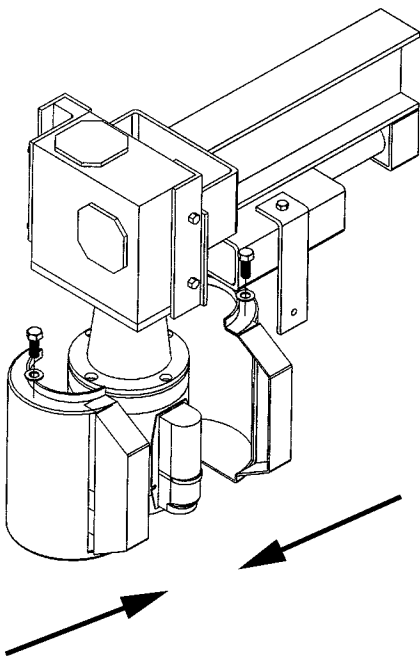

M. Standard profile motor cover.

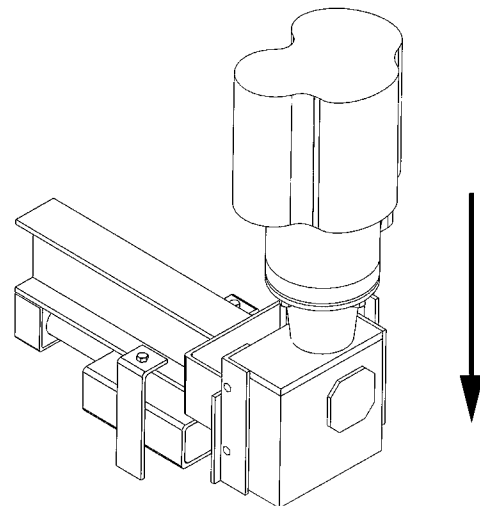

Application of silicone to top of motor before installation will help retain cover in high winds.

Boat Fitment

Take care to clear shafts, thru-hull fittings, chines, etc. Keel of boat must not rest on lifter beam and should clear beam by at least one inch. Center of gravity of boat must be in center of lift (bow to stern). This will evenly distribute the load over the two lifter beams.

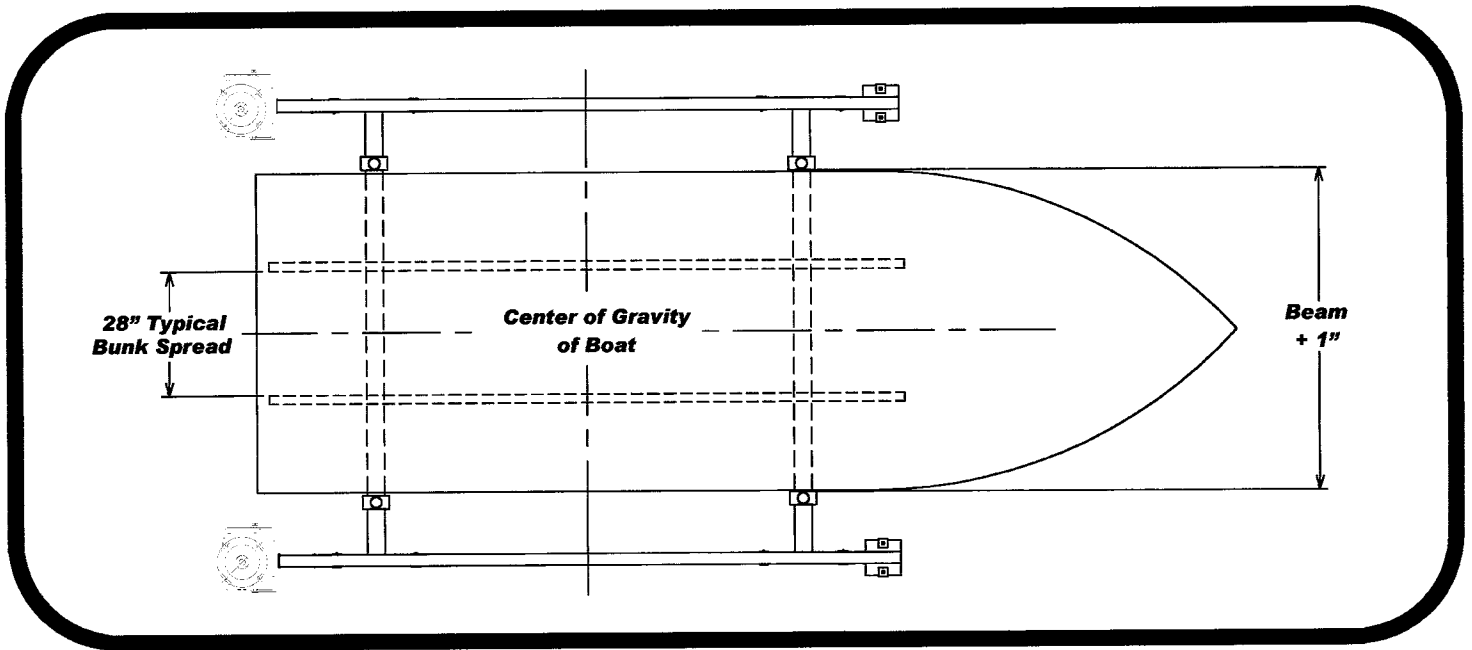

Helpful Hints:

- **A reference mark can be placed on a guide pole to indicate that the cradle is deep enough for the boat's hull to clear the cradle. This will assure clearance entering and leaving the cradle as the tide changes.**
- **For shallow water installations, a reference mark can be placed on a cable to indicate that the cradle has contacted bottom. Turning lift off at this point will prevent the cable winds from being tangled. If shallow water conditions exist, Hi-Tide strongly recommends the fitment of a limit switch.**

Important Notes to Installer:

It is the responsibility of the Installer to insure that:

- 1) The Installation is completed according to the manufacturer's recommendations.**
- 2) The ultimate user understands how to operate in a safe manner.**
- 3) The ultimate user acknowledges the need for regular service and maintenance of the lifting equipment by an authorized Hi-Tide dealer.**
- 4) The Customer is informed and understands all safety and warning labels affixed to the equipment.**

No alterations or modifications may be made to Hi-Tide equipment without the expressed written consent of Hi-Tide Sales, Inc. Re-installation of Hi-Tide equipment must be performed by an authorized Hi-Tide Agent/Dealer and must be performed to the standards set forth by Hi-Tide Sales, Inc. Transfer of any remaining warranty to a new location is solely at the discretion of Hi-Tide Sales, Inc. It is the obligation of the re-installer to inform any new operators of the above conditions. Maintenance/Owners Manuals and Safety Warning Decals are available on request from Hi-Tide Sales, Inc.